

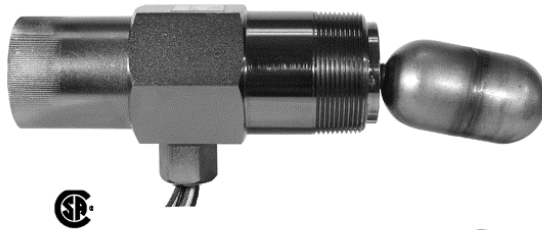

by **ENOVATION** CONTROLS

**Electric Switch**



**Pneumatic Switch**

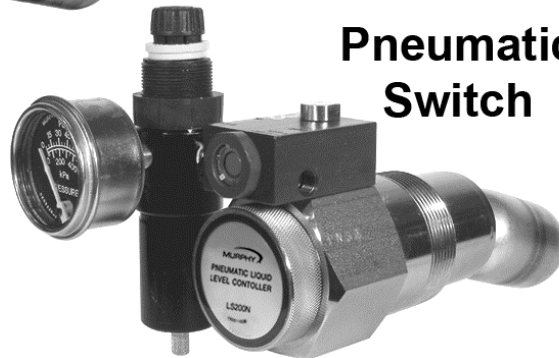

# **LS200, LS200N and LS200NDVOR Series Liquid Level Switches**

***Installation and Operations Manual***

In order to consistently bring you the highest quality, full-featured products, we reserve the right to change our specifications and designs at any time. The latest version of this manual can be found at [www.fwmurphy.com](http://www.fwmurphy.com).

**Warranty** - A limited warranty on materials and workmanship is given with this Murphy product. A copy of the warranty may be viewed or printed by going to <http://www.fwmurphy.com/warranty>.



**CAUTION: LS200 Series parts are not interchangeable with other Murphy liquid level products. Damage caused by using incorrect parts is not covered by our Limited Warranty.**



Please read the following information before installing. A visual inspection for damage during shipping is recommended before mounting.

**BEFORE BEGINNING INSTALLATION OF THIS MURPHY PRODUCT:**

Disconnect all electrical power to the machine.

Make sure the machine cannot operate during installation.

Follow all safety warnings of the machine manufacturer.

Read and follow all installation instructions.

OBSERVE all pressure and electrical ratings and requirements for the devices and the operating environment.

BE SURE all pressure HAS BEEN REMOVED from the vessel before opening any pressure connections.

Please contact Enovation Controls immediately if you have any questions.

## Table of Contents

<b>Product Information</b> .....	<b>1</b>
Features .....	1
LS200.....	1
LS200NDVOR.....	2
LS200NDVO .....	3
LS200N.....	3
<b>Pressure Vessel Installation: LS200 and LS200N</b> .....	<b>4</b>
Direct Installation into the Wall of the Pressure Vessel .....	4
Installation with a Weld Collar .....	5
Installation Using Murphy External Float Chamber .....	5
Installation and Adjustment for Pneumatic Models.....	6
<b>Replacing and Installing the DVO Assembly</b> .....	<b>7</b>
Models LS200NDVO & LS200NDVOR .....	7
<b>Electrical</b> .....	<b>9</b>
<b>Replacement Parts</b> .....	<b>9</b>
<b>Accessories</b> .....	<b>10</b>
15050375: Weld Collar.....	10
55050617: DVU150/DVU175 Adapter Bushing.....	10
15051098: External Float Chamber .....	11
15700799: Series 100 External Float Chamber .....	11
15000478: Float Shaft Extension for the LS200.....	11
The Murphy Gas Compressor Scrubber Level System (SLS).....	12
<b>Specifications</b> .....	<b>13</b>
All Models.....	13
LS200.....	13
LS200NDVOR.....	13
LS200NDVO .....	13
LS200 N .....	13
Approximate Shipping Weights and Dimensions.....	13

**(THIS PAGE INTENTIONALLY LEFT BLANK)**

## Product Information

### Features

Listed for Class I, Div. 1, Grp. C & D locations

Canadian Registration Number OF1476.2

### Minimum Allowable Specific Gravity for LS200

Model	Float Extension length (inch)	Pressure (psi)	Specific Gravity
LS200	0	2000	0.55
	1		0.7
	6		1
LS200NDVO	0	2000	0.63
	1		0.73
	6		1.02

**\*Note:** The min. allowable SG will decrease with a decrease in operating pressure

### LS200

LS200 Liquid Level Switches with 2-inch NPT mounting are float activated to operate an electrical SPDT snap-switch (optional DPDT on some models) for alarm or shutdown of an engine or electric motor. The LS200 connects directly into the vessel wall and can be used with a Murphy weld collar (P/N 15050375) or Murphy external float chamber.

Refer to the specification table below for product dimensions.

<b>A</b>	10.18 in. (259 mm)
<b>B</b>	3.44 in. (87 mm)
<b>C</b>	1.75 in. (44 mm)
<b>D</b>	3.36 in. (85 mm)
<b>E</b>	2 NPT

**NOTE:** Refer to Table 3 and Table 4 for clearances.

## LS200NDVOR

LS200NDVOR is a float-activated, pneumatic-vent level device used to operate dump valves or similar devices.

The LS200NDVOR provides a 2-inch NPT mounting with a pneumatic output for interfacing with pneumatic devices such as our Murphy pneumatic dump valve or with other pneumatic instrumentation.

Pneumatic media devices require clean, dry, instrument-quality air or gas. This unit is supplied with a pressure regulator, filter and Murphy 20BPG pressure gage for improved system life and trouble-free operation.

VENT VALVE = 3 WAY NC SNAP ACTION WITH 1/16" [2] ORIFICE AND VITON SEAT.  
INLET: 1/8" NPT  
OUTLET: 1/4" NPT

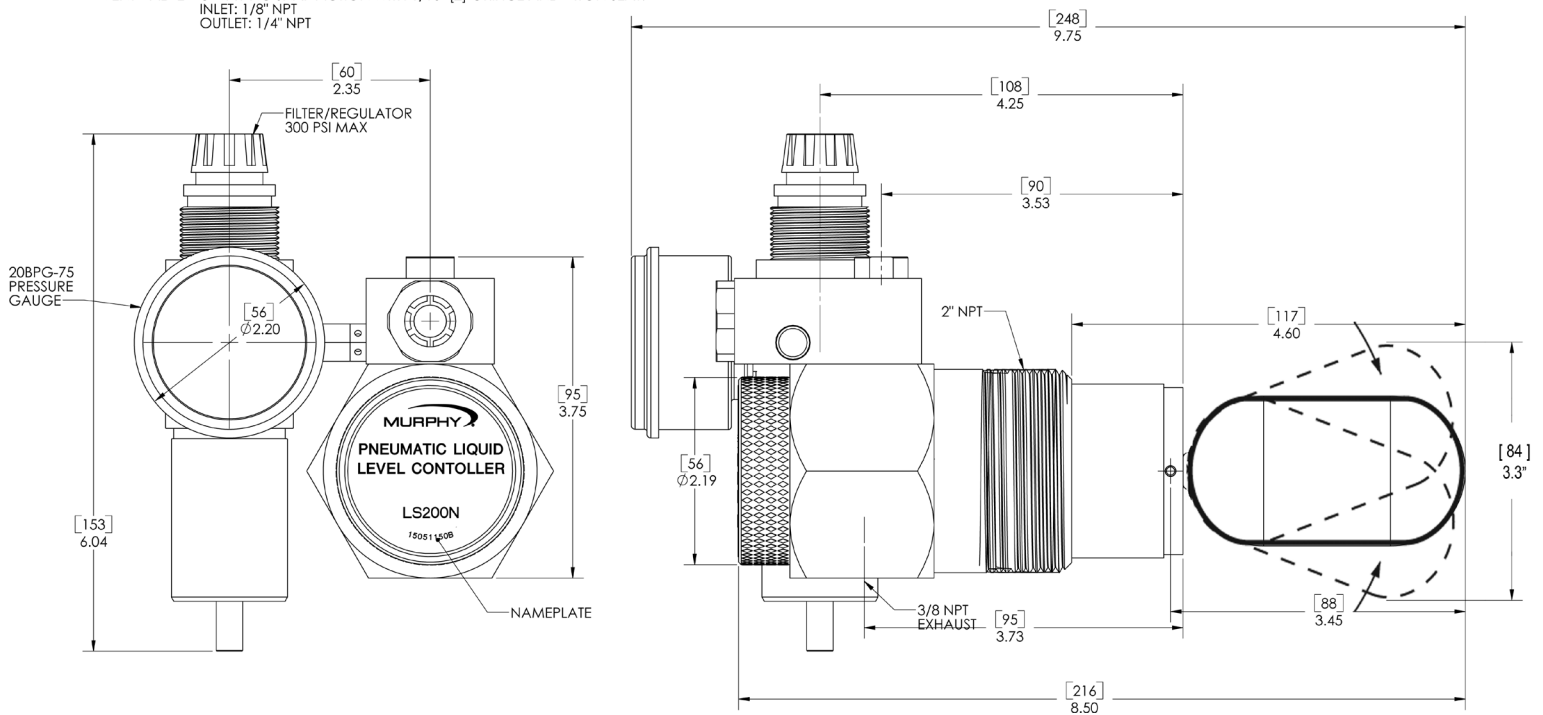

**LS200NDVOR pneumatic level switch with dump valve operator, pressure regulator and gage**

# LS200NDVO

Shown below is the Pneumatic level switch with Dump Valve Operator (DVO) without the pressure regulator (for those applications where the system provides a filter regulator for instrument-quality air or gas as the control medium).

VENT VALVE = 3 WAY NC SNAP ACTION WITH 1/16" [2] ORIFICE AND VITON SEAT.  
 INLET: 1/8" NPT  
 OUTLET: 1/4" NPT

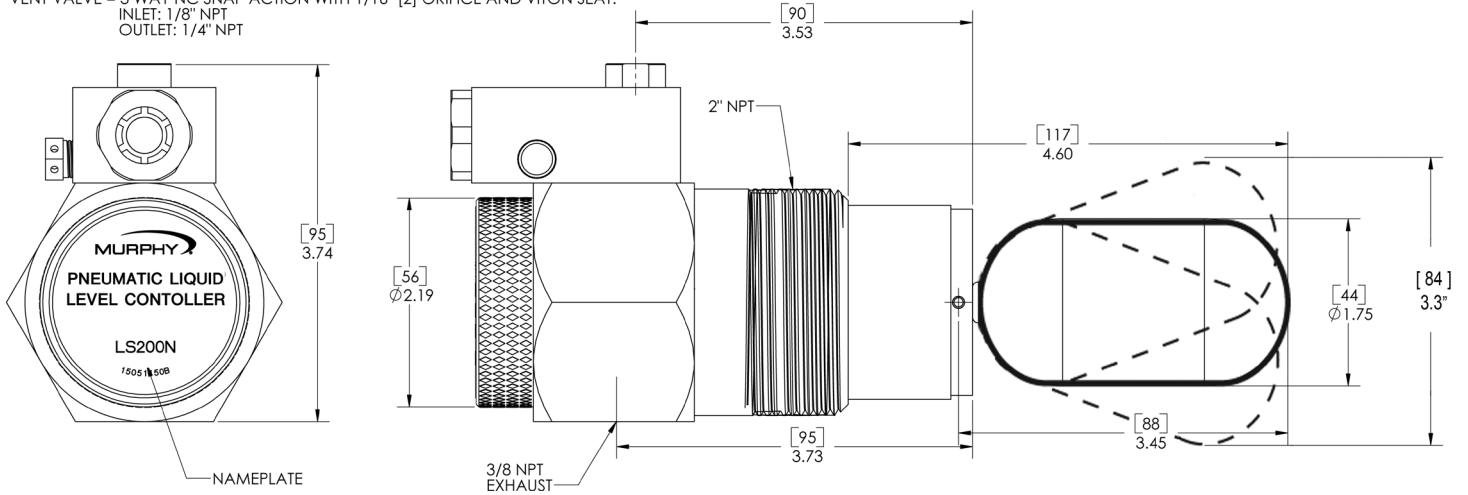

**LS200NDVO pneumatic level switch with dump valve operator**

# LS200N

Shown below is the Pneumatic level switch without the DVO and filter regulator.

VENT VALVE = 2 WAY NC SNAP ACTION WITH 1/16" [2] ORIFICE AND VITON SEAT.  
 INLET: 1/8" NPT  
 OUTLET: 1/4" NPT

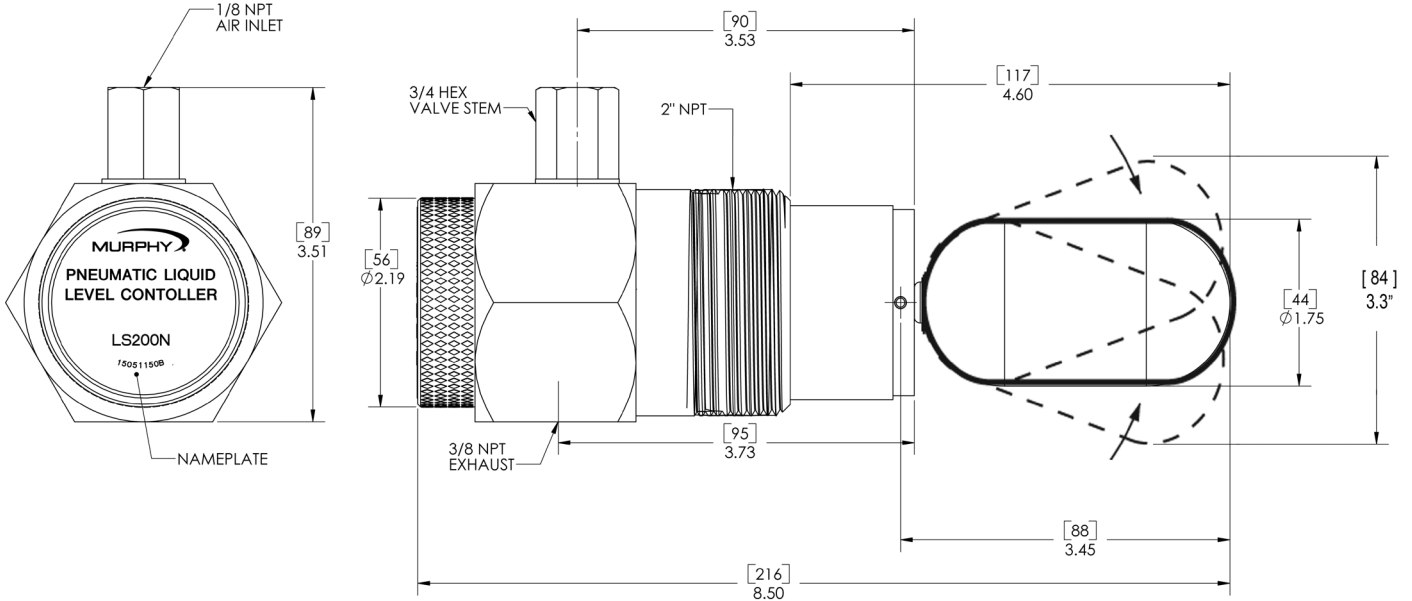

**LS200N pneumatic level switch**

# Pressure Vessel Installation: LS200 and LS200N

## Direct Installation into the Wall of the Pressure Vessel



**CAUTION: Determine that the float travel is not obstructed by the coupling in the vessel wall, internal baffles, etc. Refer to tables 1, 2, 3 and 4 for application data.**

1. Make certain the float and extension are tight.
2. Before installing the level switch, use of a pipe thread sealant is recommended. Screw the unit directly into the threaded connection in the wall of the pressure vessel.
3. For LS200, verify that the electrical connection is positioned at the bottom.
4. For LS200N the 1/8-inch NPT pneumatic connection should be on top, the 3/8-inch NPT vent connection should be on the bottom.
5. Make the electrical wiring connections according to appropriate wiring diagrams for the alarm or shut-down system to be used. The electrical connection is 1/2-inch-14 NPT.
6. Ensure all electrical connections are insulated and the cover is fully installed before reconnecting electrical power.
7. Verify all pressure connections are tight before pressurizing the system.

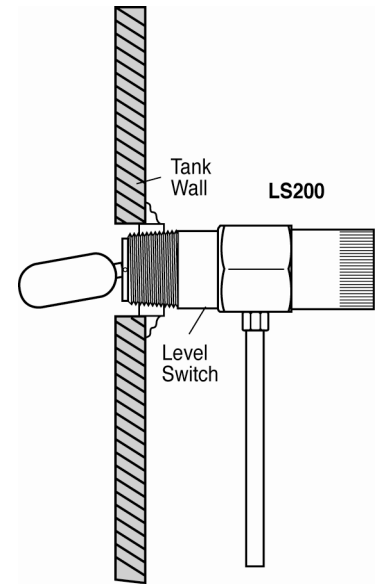

### Clearance Reference Tables

Nom. Size (inches)	O.D. (inches)	Schedule Number	Wall Thickness (inches)	Inside Diameter (inches)
3	3.5	40ST	0.216	3.068
3	3.5	80XS	0.3	2.9
4	4.5	40ST	0.237	4.026
4	4.5	80XS	0.337	3.826

Product Name	Insertion Depth (inches)		Vertical Clearance (inches)	
	Std.	w/ 1" Extension	Std.	w/ 1" Extension
LS 200	4.6	5.6	2.8	3.15
LS 200N	5.43	6.4	3.3	3.9
L 1200 *	4.65	5.7	3.9	4.55
L 1200N *	5.6	6.7	5.3	6.9

\* Included for reference. These products have been discontinued.



## Installation with a Weld Collar

1. The weld collar, P/N 15050375, must be welded into the wall of the pressure vessel according to code standards and good welding practices.
2. Follow above instructions for installation directly into the wall of the pressure vessel.

**NOTE:** Weld collar 15050375 can be used ONLY with model LS200.

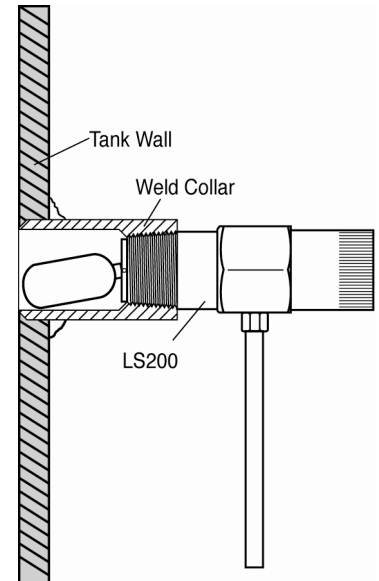

## Installation Using Murphy External Float Chamber

1. Install the Murphy float chamber 15051098 or 15700799 on the outside wall of the pressure vessel using 1-inch NPT piping or use the mounting surface with a bracket. Position the 2-inch NPT threaded connection at the height where you want the level switch to operate. The 2-inch NPT threaded connection must be positioned away from the tank wall.
2. A tee and bleed valve are typically installed at the bottom of the lower 1-inch pipe riser to allow draining of the float chamber for servicing or replacement.

**NOTE:** A typical installation with blocking and bleed valves is shown at right.

3. Install the LS200 or LS200N/NDVO/NDVOR in the 2-inch NPT connection of the float chamber. BE SURE float travel is not restricted and that the float is tight onto the float shaft.
4. To complete installation and wiring, follow the instructions for mounting directly into wall of the vessel and for wiring.

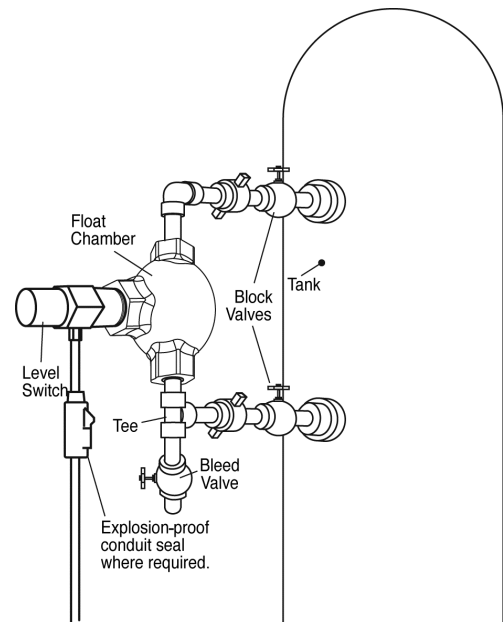

**CAUTION: Float extensions cannot be used with float chambers.**

## Installation and Adjustment for Pneumatic Models

1. All pneumatic models operate on the vent principle. **The pneumatic signal source must be clean, dry, instrument-quality air or natural gas. The input pneumatic signal must be regulated between 30 and 70 psi (207-483 kPa) [2 -4.83 bar].** If produced gas is used as the signal source, it should be taken after gas passes through the final scrubber. A suitable filter must be positioned before the LS200NDVO to prevent liquids and/or particulates from entering the dump valve operator.

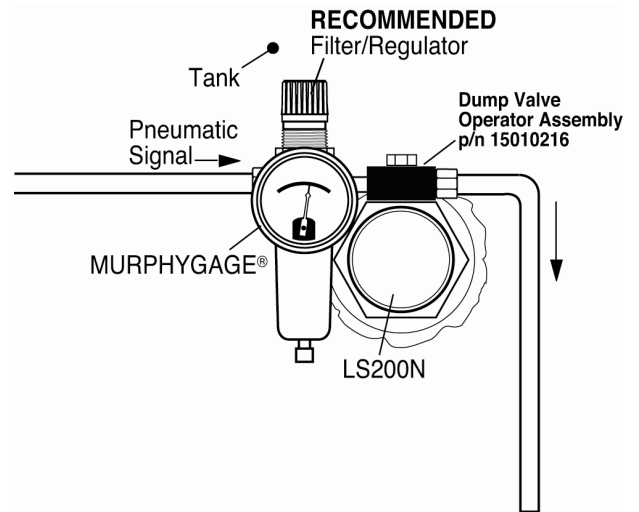

**NOTE:** Check filter periodically for wear and tear and elements that hamper the flow of the pneumatic signal.

2. All pressure connections must be tight and maintained tight so as not to leak air/gas.



**CAUTION: Avoid excessive Teflon tape which may inhibit proper operation.**

**Each switch is set to vent on rising level at the factory and should not need field adjustment. For testing the system, we have provided the red Manual Valve Operator on the operator pilot valve.**

3. Valve seat adjustment can be made if air/gas begins to leak. Care should be taken when adjusting as only slight movement is necessary to stop the leakage; excessive force will bind the seating mechanism. See the instruction below for adjustment.

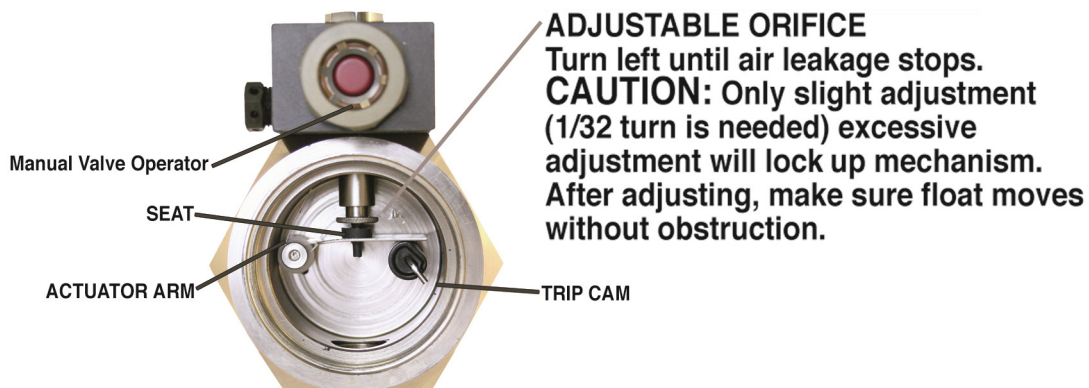

## Replacing and Installing the DVO Assembly

**NOTE:** When replacing/installing the DVO assembly, tubing and fitting modifications may be required. We suggest removing the LS200NDVO/DVOR from the vessel. Relieve pressure from the vessel or use block valves before removing the LS200NDVO/DVOR.

### Models LS200NDVO & LS200NDVOR

---

**NOTE:** Clean, dry, instrument-quality gas should be used. Use and regular maintenance of filters will improve service life and reliability.

#### Tools Needed

- 2-1/2 inch hex wrench or pipe wrench with smooth jaws
- 9/16-inch hex wrench
- Tubing cutters and benders

#### Instructions

1. Block off and bleed the instrument gas pressure supply to the LS200NDVO/DVOR.
2. Remove the tubing between the LS200NDVO/DVOR and the scrubber dump valve, and remove the supply gas tubing (regulator [-R-] if used).
3. Remove the LS200NDVO/DVOR from the vessel (optional).
4. If the LS200NDVO/DVOR was removed from the vessel, mount it in a suitable vise on a work bench (if possible).
5. Using the proper tools, disconnect the inlet, outlet and exhaust fittings from the existing DVO. See **Figure 1**. You will reconnect these to the new DVO in a later step.

**NOTE:** The following steps must be done with the DVO in the upright position (on top of the LS200NDVO).

6. Remove the LS200NDVO/DVOR cover. The use of a strap wrench or a pipe wrench may be needed.
7. With a 9/16-inch hex wrench, loosen the hex head bolt on top of the DVO, and remove the existing DVO from the body.
8. Ensure that the adjustable orifice is fully raised up so that the actuator arm is not bent when inserted into the body. See **Figure 2**.
9. Insert the new DVO into the body. The DVO manual valve operator must face away from the vessel. See **Figure 3**.

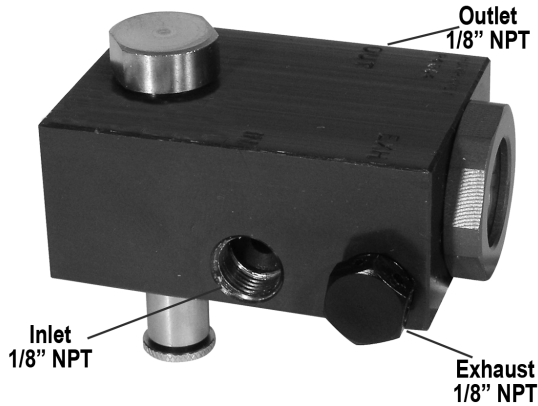

**Figure 1 - DVO**

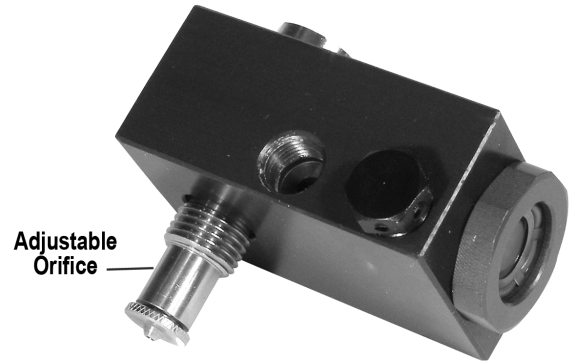

**Figure 2 – Adjustable Orifice**



**CAUTION: Ensure that the actuator arm is not bent during reassembly**

10. With the DVO aligned over the hex on the LS200NDVO body, tighten the valve using the 9/16-inch hex wrench. You may need to hold the DVO while tightening to keep it from rotating.
11. The pneumatic input signal should be regulated between 30 and 70 psi for proper setting of the adjustable orifice. With the float in the down position, adjust the adjustable orifice down until it touches the seat. See **Figure 4**.

If the DVO is still leaking, make slight adjustments (1/32 turn). Excessive adjustments will lock up mechanisms. After adjusting, make sure float moves freely up and down.

12. Replace the LS200NDVO/DVOR cover.
13. Using the appropriate tools reinstall the inlet, outlet and exhaust fittings to the new DVO.

**NOTE:** Thread sealant is recommended although care should be used to not allow excess to enter valve.



**Figure 3 – DVO manual valve operator**

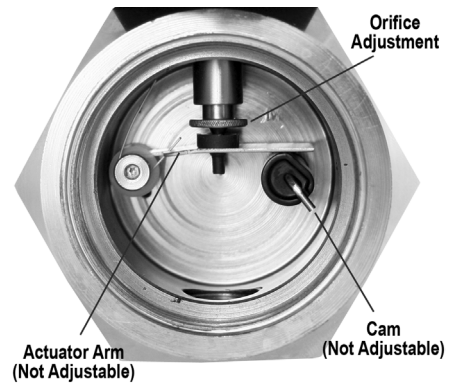
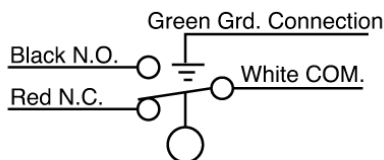

**Figure 4 – Orifice Adjustment with float in down position**

14. Connect to the inlet, outlet and exhaust fittings according to installation drawings.

## Electrical

### SPDT (snap-switch)



**Switch Rating:** 5 A @ 125-250- 480 VAC  
 1/2 A @ 125 VDC  
 1/4 A @ 250 VDC  
 2A @ 6-30 VDC Resistive  
 1A @ 6-30 VDC Inductive

### DPDT (snap-switch)

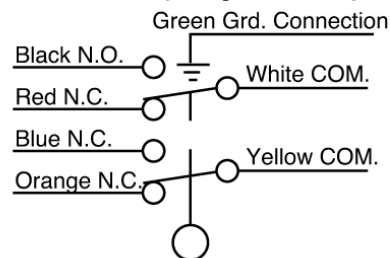

**Switch Rating:** 10 A @ 125-250 VAC  
 1/2 A @ 125 VDC  
 1/4 A @ 250 VDC  
 10 A @ 6-24 VDC  
 Inductive/Resistive

## Replacement Parts

Order by part number designation.

### LS200

- 15000479: Stainless steel float for LS200 (not interchangeable with L1200)
- 15000124: SPDT snap-switch assembly
- 15000478: 1-inch float shaft extension (not interchangeable with L1200)

### LS200N

- 15000479: Stainless steel float for LS200N (not interchangeable with L1200)
- 15051133: Valve stem

## LS200NDVO and LS200NDVOR

55050621: Regulator only

05704480: 20BPG-D-75 Square Port Pressure Murphygage®  
0-75 psi (517 kPa) [5.17 bar]

15000237: Regulator Gauge Assembly (includes regulator, gauge and fittings)

15010267: Assembly (**LS200N DVO Assembly**)

## Accessories

### 15050375: Weld Collar

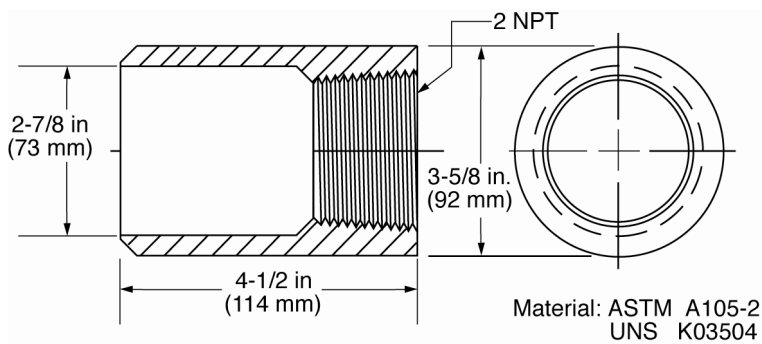

Operating pressure: 2000 psi (13.8 MPa) [138 bar].

Operating temperature: 400°F (204°C).

### 55050617: DVU150/DVU175 Adapter Bushing

Order by part number designation

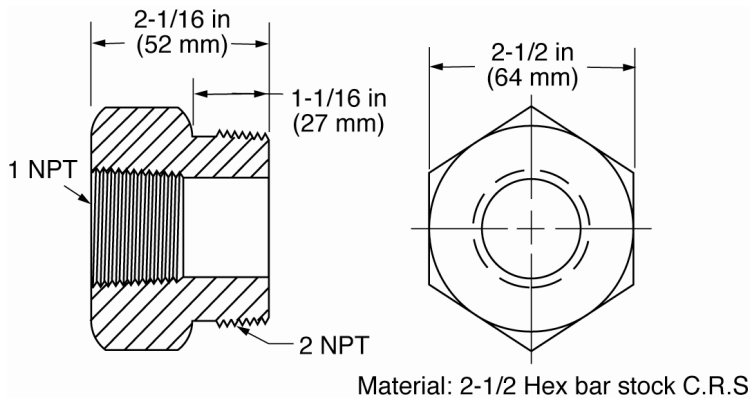

## 15051098: External Float Chamber

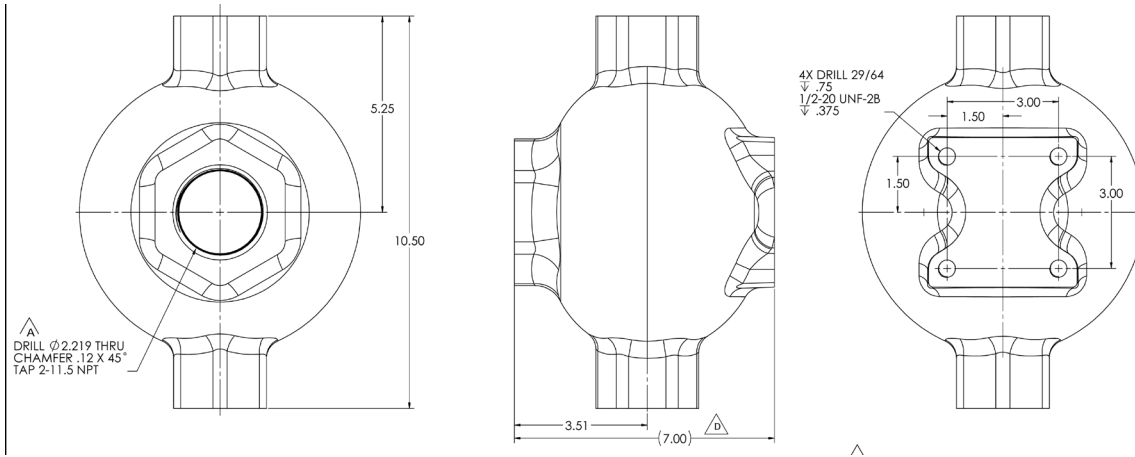

Operating pressure: 2000 psi (13.8 MPa) [138 bar]  
 Operating temperature: 400°F (204°C).

## 15700799: Series 100 External Float Chamber

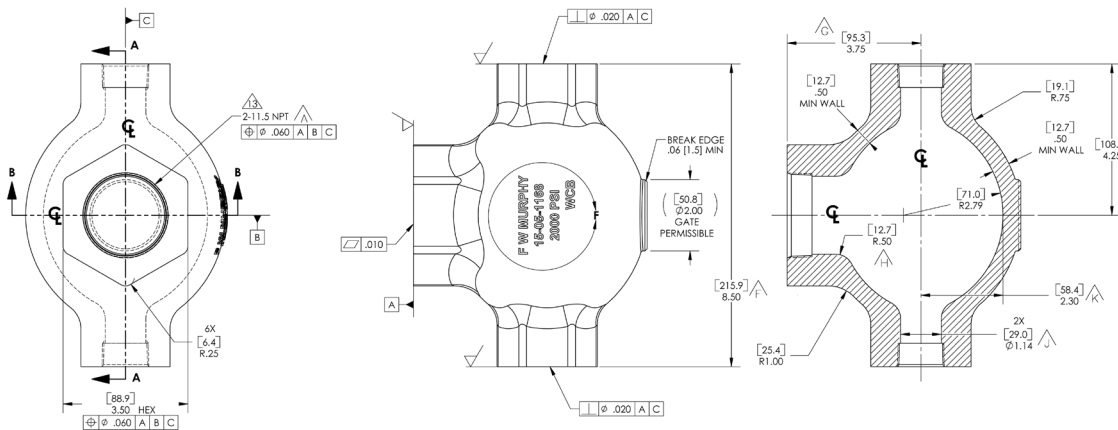

Operating pressure: 2000 psi (13.8 MPa) [138 bar]  
 Operating temperature: 400°F (204°C).

## 15000478: Float Shaft Extension for the LS200

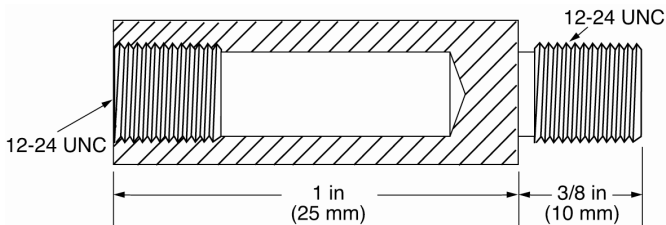

Material: AISI 303, UNS-S30300



**CAUTION: Use of 1-inch extension requires additional clearance. Refer to Tables 1, 2, 3 and 4 for application data.**

# The Murphy Gas Compressor Scrubber Level System (SLS)

The system provides for liquid control in gas scrubber applications, by dumping liquids to drain and protecting compressors with a high liquid level switch. Wetted metal parts are made to survive constant use in corrosive environments.

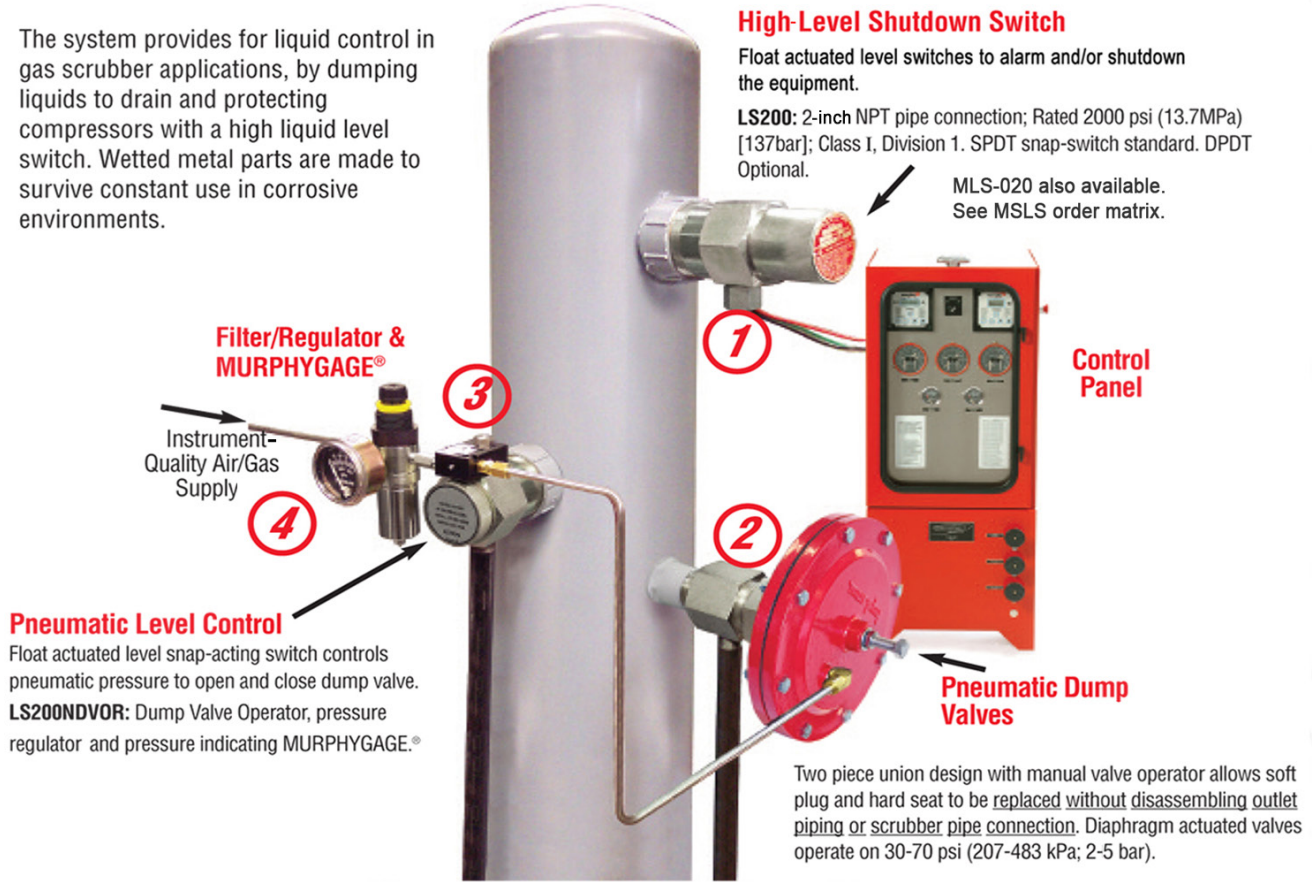



## Specifications

---

### All Models

---

Listed for Class I, Div. 1, Grp. C & D locations

Canadian Registration Number OF1476.2

Body: Nickel-plated steel; optional 316 stainless steel

Float: 304 stainless steel

Pressure rating: 2000 psig (13.8 MPa) [138 bar] (LS200 models only)

O-ring: Viton

Process connection: 2" NPT

Temperature rating: -20 to 300°F (-29 to 149°C)

### LS200

---

Electrical: SPDT std. (see Electrical section for configuration/rating)

Wiring: 18 AWG x 36 in. (1.0 mm<sup>2</sup> x 916 mm)

### LS200NDVOR

---

DVO valve: 3-way N.C. w/manual operator, all connections 1/8" NPT (minimum 30 psig required)

Filter/pressure regulator set:

Regulator: 0 to 75 psig (0 to 517 kPa) [0 to 5.17 bar] range

Maximum input pressure: 300 psig (2.07 MPa) [20.7 bar]

### LS200NDVO

---

DVO valve: 3-way N.C. w/manual operator; all connections 1/8" NPT

### LS200 N

---

Vent valve: 2-way N.C. w/ 1/16in. (2mm) orifice and Viton seat; Inlet: 1/8" NPT; outlet 3/8" NPT

### Approximate Shipping Weights and Dimensions

---

All models: 6 lb. 10 oz. (3 kg)

Dimensions: (w x h x d) 10.18 x 3.36 x .11 in. (259 x 85.34x 2.88 mm)

## NOTES

## NOTES

In order to consistently bring you the highest quality, full-featured products, we reserve the right to change our specifications and designs at any time. MURPHY products and the Murphy logo are registered and/or common law trademarks of Enovation Controls, LLC. This document, including textual matter and illustrations, is copyright protected by Enovation Controls, LLC, with all rights reserved. (c) 2016 Enovation Controls, LLC. A copy of the warranty may be viewed or printed by going to [www.fwmurphy.com/warranty](http://www.fwmurphy.com/warranty).

**ENOVATION CONTROLS CORPORATE HEADQUARTERS**

5311 S 122ND EAST AVENUE  
TULSA, OK 74146

**ENOVATION CONTROLS – SAN ANTONIO OFFICE**

5757 FARINON DRIVE  
SAN ANTONIO, TX 78249

**ENOVATION CONTROLS – HOUSTON OFFICE**

105 RANDON DYER RD  
ROSENBERG, TX 77471

**ENOVATION CONTROLS LTD. – UNITED KINGDOM**

CHURCH ROAD LAVERSTOCK  
SALISBURY SP1 1QZ UK

**MURPHY ECONTROL TECHNOLOGIES (HANGZHOU) CO, LTD.**

77 23RD STREET  
HANGZHOU ECONOMIC & TECHNOLOGICAL DEVELOPMENT AREA  
HANGZHOU, ZHEJIANG 310018 CHINA

**U.S. SALES & SUPPORT**

**ECONTROL PRODUCTS**

PHONE: 210 495 9772  
FAX: 210 495 9791  
EMAIL: [INFO@ENOVATIONCONTROLS.COM](mailto:INFO@ENOVATIONCONTROLS.COM)  
[WWW.ECONTROL.COM](http://WWW.ECONTROL.COM)

**MURPHY PRODUCTS**

PHONE: 918 317 4100  
FAX: 918 317 4266  
EMAIL: [SALES@ENOVATIONCONTROLS.COM](mailto:SALES@ENOVATIONCONTROLS.COM)  
[WWW.FWMURPHY.COM](http://WWW.FWMURPHY.COM)

**MURPHY CONTROL SYSTEMS & SERVICES**

PHONE: 281 633 4500  
FAX: 281 633 4588  
EMAIL: [CSS-SOLUTIONS@ENOVATIONCONTROLS.COM](mailto:CSS-SOLUTIONS@ENOVATIONCONTROLS.COM)

**MURPHY INDUSTRIAL PANEL DIVISION**

PHONE: 918 317 4100  
FAX: 918 317 4124  
EMAIL: [IPDSALES@ENOVATIONCONTROLS.COM](mailto:IPDSALES@ENOVATIONCONTROLS.COM)

**INTERNATIONAL SALES & SUPPORT**

**UNITED KINGDOM**

PHONE: +44 1722 410055  
FAX: +44 1722 410088  
EMAIL: [SALES@ENOVATIONCONTROLS.EU](mailto:SALES@ENOVATIONCONTROLS.EU)  
[WWW.FWMURPHY.EU](http://WWW.FWMURPHY.EU)

**CHINA**

PHONE: +86 21 6237 5885  
FAX: +86 21 6237 5887  
EMAIL: [APSALES@ENOVATIONCONTROLS.COM](mailto:APSALES@ENOVATIONCONTROLS.COM)

**LATIN AMERICA & CARIBBEAN**

PHONE: 918 317 2500  
EMAIL: [LASALES@ENOVATIONCONTROLS.COM](mailto:LASALES@ENOVATIONCONTROLS.COM)

**SOUTH KOREA**

PHONE: +82 70 7951 4100  
EMAIL: [SKOREASALES@ENOVATIONCONTROLS.COM](mailto:SKOREASALES@ENOVATIONCONTROLS.COM)

**INDIA**

PHONE: +91 91581 37633  
EMAIL: [INDIASALES@ENOVATIONCONTROLS.COM](mailto:INDIASALES@ENOVATIONCONTROLS.COM)



FM 28221 (Tulsa, OK - USA)  
FM 620667 (San Antonio, TX - USA)  
FM 28221 (Rosenberg, TX - USA)  
FM 29422 (UK)



FM 523851 (China) TS 589322 (China)